

Sanitary Type Electronic Flow Switches

Industries

Pharmaceutical

Food and Beverage

Biotechnology

Semiconductor

Water Treatment



SX Series

Ameritrol, Inc.
Instruments and Controls

Features

- No Moving Parts
- 316L Stainless Steel
- Temperatures to +350F
- Simple and Easy Field Calibration
- Explosion Proof Nema 4X Enclosure
- Low Flow Rate Detection
- Sanitary Process Connections
- 3A Sanitary Design
- Field Programmable Relay Energization
- Special Ra Polish & Electropolishing



SX-1005 with 1 1/2" Short Leg Tee



Optional Remote Mounted Electronics



SX-1005-1.0 with Instrument Tee

Specifications

Sensor Head

Material of Construction:	316L Stainless Steel Standard Option Electropolished to 15Ra
Operating Temperature:	-50 to +350F (-46 to +177C) Standard
Operating Pressure:	Vacuum to 2000 PSIG (207 Bar)
Response Time:	From 3 Seconds
Repeatability:	± 0.5% of Range at Constant Conditions
Process Connection:	1 1/2", 2" Tri-Clamp Cap Standard Option 3", 4" Tri-Clamp Cap
Probe Length:	1.8", 1.0"; Option Customer Specified

Electronics

Housing:	Powder Coated Explosion Proof, Nema 4X, UL/CSA Rated to Class 1, Div. 1 & 2, Group B,C,D; Class II, Div. 1 & 2, Group E,F,G; Class III. Option FM and Cenelec/ATEX
Temperature:	-50 to +150F (-46 to +65C)
Power Input:	120 VAC, 50/60 Hz, 4 Watts; Options: 24 VDC/VAC, 240VAC
Output:	SPDT 3 Amps Resistive Standard See page 4 for options
Electrical Connection:	1" FNPT
Shipping Weight:	5 lbs

Operation

The SX sanitary series flow switch has been designed to meet the most critical flow detection applications in the food, pharmaceutical, biotechnology, and water treatment industries. Quick disconnect tri-clamp caps are standard with special finishes for 3A applications and polished/electropolished for biotechnology and pharmaceutical use.

The thermal dispersion principle of operation features no moving parts exposed to the process. The instrument operates by measuring a temperature differential between a heated and a reference temperature sensor (see figure 1). An extremely low power heating element is attached to a temperature sensor and a second temperature sensor is isolated from the heater to provide compensation for changing process temperature. The electronics measure the differential and can be adjusted to switch at any flow listed in the flow switch set-point range chart.

Extremely low flow rates such as .04 GPM in a 1" line can be detected with rangeability up to 300:1. These flow switches can be used in virtually all liquids, gases, and slurries.

The electronics are available with single or dual switch points. Temperature monitoring is also available with either a switch output or a linear 4-20 mA output.

Relay outputs are standard and are offered with several different configurations and contact ratings. Remote mounting of the electronics is also available.

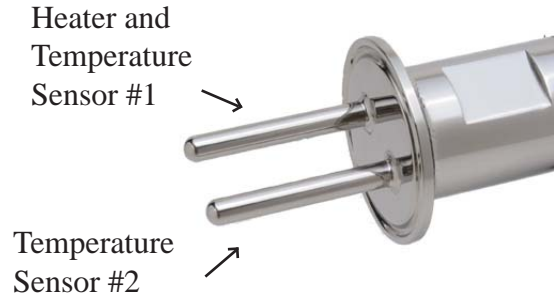

$$\text{Temperature Differential} = \text{Temperature Sensor \#1} \text{ Minus Temperature Sensor \#2}$$

Figure 1

Flow Switch Set-Point Range

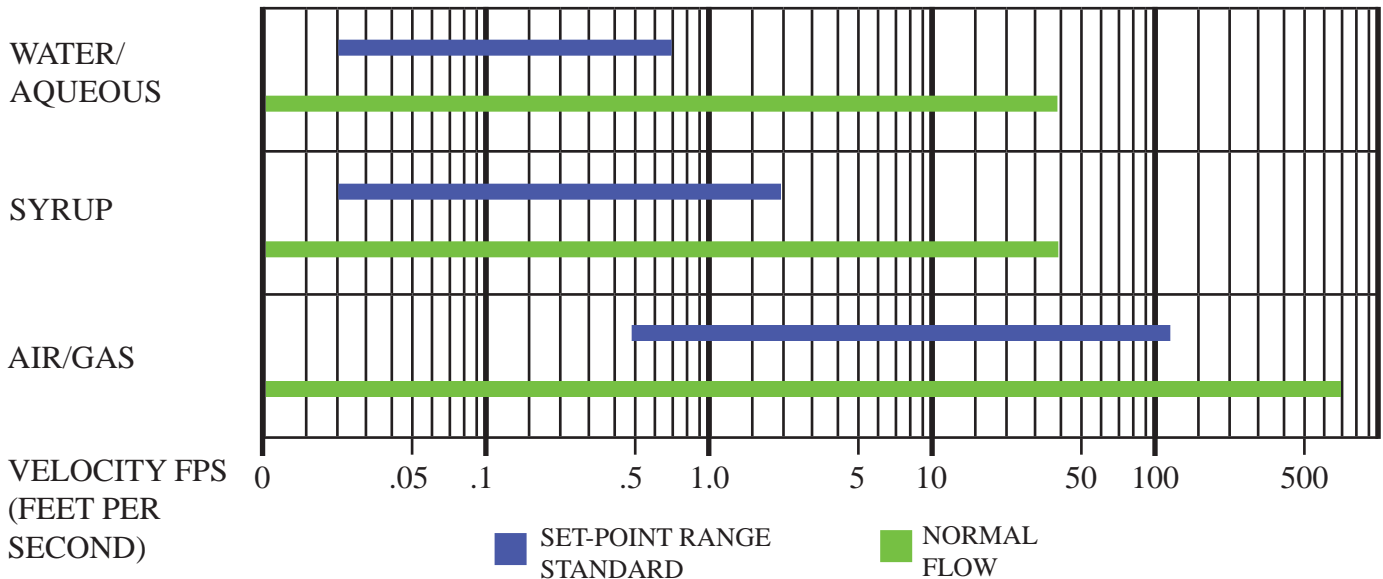

Conversion Table

Volumetric (GPM or CFM) to Velocity (Feet per Second - FPS)

Pipe Size	1/8"	1/4"	3/8"	1/2"	3/4"	1"	1.25"	1.5"	2"	2.5"	3"	3.5"	4"	5"	6"
Liquid Multiplier	5.65	3.08	1.68	1.06	.602	.371	.215	.158	.096	.067	.0434	.0325	.0252	.0160	.0111
Air Multiplier	42.19	23.06	12.57	7.91	4.50	2.78	1.61	1.18	.716	.502	.325	.243	.188	.120	.083

Tube Size	1/2"	3/4"	1"	1.5"	2"	3"	4"	6"
Liquid Multiplier	2.21	.884	.473	.200	.1086	.0476	.0265	.01162
Air Multiplier	16.5	6.61	3.53	1.49	.812	.356	.198	.0869

Examples:
 1) 100 CFM in 3" Tube = 100 x .356 = 35.6 FPS
 2) 10 GPM in 3" Tube = 10 x .0476 = .476 FPS

Circuit Board Options

Standard Single Switch Point Electronics

- SPDT relay output with 3 or 10 amp contacts
- DPDT relay option with 3 or 10 amp contacts
- Wide selection of power inputs including 24 VAC or VDC, 120 VAC, or 240 VAC

This circuit board is the standard used in the SX series flow switches. The electronics offer constant current sensor excitation, precision signal amplification, and highly repeatable switching circuitry for reliable operation in even the most demanding applications.



Optional Dual Switch point Electronics

- Two separately adjustable switch points
- SPDT relay output for each set point with 3 or 10 amp contacts
- Power inputs include 24 VAC or VDC, 120 VAC, or 240 VAC

The optional dual switch point electronics provide two independently adjustable switch points that can be used to detect any two combinations of decreasing and/or increasing flow.



Single Switch Point Electronics with Additional Temperature Transmitter

- Temperature transmitter (3 wire 100 Ohm platinum RTD sensor) with loop powered 4-20 mA output
- SPDT relay output for flow switch with 3 or 10 amp contact rating
- Flow switch power inputs include 24 VAC or VDC, 120 VAC, or 240 VAC

This option provides the user with a highly reliable flow switch with an accurate temperature transmitter. The temperature transmitter provides a industry standard linearized 4-20 mA signal. The temperature output is loop powered and can operate from 8-36 VDC.



Single Switch Point Electronics with Additional Temperature Switch

- Temperature switch point available from -50F to +350F
- SPDT relay output for flow and temperature with 3 or 10 amp contact rating
- Customer specified power inputs include 24 VAC or VDC, 120 VAC, or 240 VAC

This optional circuit board monitors two process variables, flow and temperature, with one instrument. Cost savings are realized by the user since the instrument has only one process connection and one conduit run. Applications include monitoring cooling water and all other applications shown on page 5 of this brochure.



Optional Calibrator

Flow Switch Calibrator Model MC-5

- Displays mV output which is proportional to flow
- Induces signal to electronics for setting specified switch point
- Allows periodic switch point verification

This tool is not needed for a vast majority of users. It is useful when a user has large quantity of units and requires periodic verification of switch point calibrations.

This easy to use hand held, self powered instrument can be used in conjunction with all single or dual switch point circuit boards. By simply plugging this instrument into the circuit board, the user can interrogate all functions of the flow switch.



Flow Switch Applications

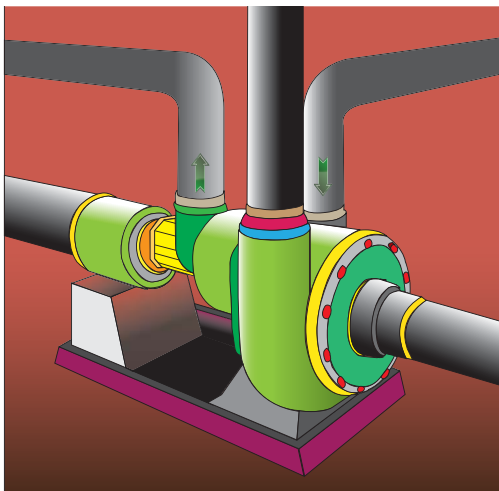

- Suitable for CIP systems
- Pump Protection: Automatic shut down on low or no flow
- Control Rooms: Verifies flow when fans, pumps or valves are energized
- Reliably used in extremely viscous fluids
- Electropolished sensors available
- Relief Valve/Rupture Disks: Alarms on flow or leakage of safety relief valves or rupture disks

- Spray Nozzles: Detects nozzle blockage in coating applications
- Purge Air: Detects loss of flow for process or plant safety
- Chiller Lines: Automatic shut down of chillers on low or no flow
- Heater Burnout Prevention: Heater shutdown on loss of flow to prevent overheating of elements
- Drain Line Sensor: Capable of detecting flow in partially filled lines
- Deionized/ Ultrapure Water Flow Sensor
- Agitation Monitor: Positive indication of agitation in tanks

