

AMERITROL, INC.

INSTALLATION
OPERATION MANUAL
AND
WIRING DIAGRAM

TX SERIES
TEMPERATURE SWITCH

Manual Number: TX2145-1

1185L Park Center Dr. Vista CA 92081
1-760-727-7273
1-800-910-6689
1-760-727-7151 Fax
www.ameritrol.com

OVERVIEW

The TX Series is an electronic temperature switch designed to detect the increase or decrease of temperature with two separately adjustable switch points. Please refer to attached wiring diagram for DIP switches and relay energization switch settings (S1 and S2).

- The temperature switch factory default settings are configured for -50 to +220F and relay energized below set point.
- To change from factory default to -50 to +130F: Change DIP switch(es) positions 1 and 2 to ON for the desired switch point.
- To change from factory default to -50 to +450F: Change DIP switch(es) positions 1 to ON and 2 to OFF for the desired switch point.
- To change from factory default to -50 to +900F: Change DIP switch(es) positions 1 and 2 to OFF for the desired switch point.
- To change from factory default relay energization of Switch Point #1 to relay energized at no flow: Reverse red slide switch (S1).
- To change from factory default relay energization of Switch Point #2 to relay energized at no flow: Reverse red slide switch (S2).
- Power input and relay rating are written on the board.

INSTALLATION

Conduit Recommendation: Do not place Temperature Switch at low point of conduit, because moisture can collect at the low point. A conduit seal may be beneficial in preventing moisture from entering the enclosure and damaging the electronics.

Install Temperature Switch into process. The TX Temperature Switch is typically mounted to a pipeline or vessel using a threaded or flange connection. The flats on the sensor allow the user to install the device using a wrench that is attached to the flats. The unit can also be attached to a bracket for monitoring ambient air temperature.

For mounting threaded units to process lines, it is recommended that:

A half-coupling, thread-o-let or the like be used. It is ideal for probes to extend into the line being monitored.

If a pipe Tee is used, it is recommended that the leg used to mount the temperature switch be the same as the instrument size (1" MNPT typical). The standard length switch sensor (1.8" long) will fit in a 1-1/4" X 1-1/4" X 1" or larger Tee.

For mounting flanged units, bolt holes will straddle the process line. Probe length ("U") is specified as the distance from the face of the flange to the tip of the probe.

For liquid service, fill the process line so that the probe is surrounded by liquid.

See attached drawing for wiring details.

CALIBRATION

When removing housing cover, observe safety precautions associated with the area in which the unit is mounted.

Dual switch point units have two separately adjustable switch points, each with a corresponding relay that can be set to be energized below or above the temperature set point.

The temperature switch uses a 1000 ohm platinum RTD for its primary sensor. The table at the end of this manual shows the resistance versus temperature of the sensor. Calibration of this device can be accomplished by either of the following methods.

1. Look up desired set point in chart and substitute that resistance for the sensors RTD. A decade box or potentiometer can be used. Follows adjustment shown below.
2. Expose sensor to desired temperature set-point and adjust as shown below.
3. A resistor connected to terminals 4 and 5 of TB2 sets the minimum temperature that the potentiometer can be adjusted to. In high temperature applications this resistor can be changed to increase the resolution of the set point. Consult the table at the end of this manual to determine the minimum set point versus resistor value.

Power the instrument and adjust as follows:

TO DETECT AN INCREASE IN TEMPERATURE (FACTORY DEFAULT):

It is assumed that the user will have the relay energized below the set-point and will alarm (relay de-energize) on increasing temperature. Please refer to attached wiring diagram for relay energization programming.

Adjust the potentiometer (R22 for switch point #1 and/or R8 for switch point #2 on the wiring diagram) on the circuit board until the LED (Red for switch point #1 and YELLOW for switch point #2) changes state, as follows:

If the LED is on: Turn the potentiometer clockwise.

If the LED is off: Turn the potentiometer counterclockwise.

Typical backlash for the potentiometer is 1/8 turn.

Locate the point where the relay just turns on and the unit is calibrated.

TO DETECT DECREASE IN TEMPERATURE:

It is assumed that the user will have the relay energized above the set-point and will alarm (relay de-energize) on decreasing temperature. Please refer to attached wiring diagram for relay energization programming. The relay energization switch (red slide switch: S1) will need to be changed from the factory default setting.

Adjust the potentiometer (R22 for switch point #1 and/or R8 for switch point #2 on the wiring diagram) on the circuit board until the LED (Red for switch point #1 and YELLOW for switch point #2) changes state, as follows:

If the LED is on: Turn the potentiometer counterclockwise.

If the LED is off: Turn the potentiometer clockwise.

Typical backlash for the potentiometer is 1/8 turn.

Locate the point where the relay just turns on and the unit is calibrated.

Technical service hours are Monday – Friday from 8:00 AM to 4:30 PM Pacific Standard Time

Temp °F	- 0	- 1	- 2	- 3	- 4	- 5	- 6	- 7	- 8	- 9
-50	825.093	822.942	820.790	818.639	816.486	814.334	812.181	810.027	807.873	
-40	846.575	844.429	842.282	840.135	837.988	835.840	833.691	831.542	829.393	827.243
-30	868.013	865.871	863.729	861.586	859.443	857.300	855.156	853.011	850.866	848.721
-20	889.407	887.269	885.131	882.993	880.854	878.715	876.575	874.435	872.295	870.154
-10	910.758	908.625	906.491	904.357	902.223	900.088	897.952	895.816	893.680	891.544
-0	932.069	929.940	927.810	925.680	923.549	921.419	919.287	917.156	915.024	912.891

Temp °F	+ 0	+ 1	+ 2	+ 3	+ 4	+ 5	+ 6	+ 7	+ 8	+ 9
0	932.069	934.198	936.326	938.454	940.582	942.709	944.836	946.963	949.089	951.214
10	953.340	955.465	957.589	959.713	961.837	963.961	966.084	968.206	970.328	972.450
20	974.572	976.693	978.814	980.934	983.054	985.173	987.293	989.411	991.530	993.648
30	995.766	997.883	1000.00	1002.12	1004.23	1006.35	1008.46	1010.58	1012.69	1014.81
40	1016.92	1019.04	1021.15	1023.26	1025.37	1027.49	1029.60	1031.71	1033.82	1035.93
50	1038.04	1040.15	1042.26	1044.37	1046.48	1048.59	1050.70	1052.80	1054.91	1057.02
60	1059.12	1061.23	1063.34	1065.44	1067.55	1069.65	1071.76	1073.86	1075.96	1078.07
70	1080.17	1082.27	1084.37	1086.48	1088.58	1090.68	1092.78	1094.88	1096.98	1099.08
80	1101.18	1103.28	1105.37	1107.47	1109.57	1111.67	1113.76	1115.86	1117.96	1120.05
90	1122.15	1124.24	1126.34	1128.43	1130.53	1132.62	1134.71	1136.81	1138.90	1140.99

Temp °F	+ 0	+ 1	+ 2	+ 3	+ 4	+ 5	+ 6	+ 7	+ 8	+ 9
100	1143.08	1145.17	1147.26	1149.35	1151.44	1153.53	1155.62	1157.71	1159.80	1161.89
110	1163.98	1166.07	1168.15	1170.24	1172.33	1174.41	1176.50	1178.58	1180.67	1182.75
120	1184.84	1186.92	1189.01	1191.09	1193.17	1195.25	1197.34	1199.42	1201.50	1203.58
130	1205.66	1207.74	1209.82	1211.90	1213.98	1216.06	1218.14	1220.21	1222.29	1224.37
140	1226.45	1228.52	1230.60	1232.67	1234.75	1236.82	1238.90	1240.97	1243.05	1245.12
150	1247.19	1249.27	1251.34	1253.41	1255.48	1257.55	1259.62	1261.69	1263.76	1265.83
160	1267.90	1269.97	1272.04	1274.11	1276.18	1278.25	1280.31	1282.38	1284.45	1286.51
170	1288.58	1290.64	1292.71	1294.77	1296.84	1298.90	1300.96	1303.03	1305.09	1307.15
180	1309.21	1311.28	1313.34	1315.40	1317.46	1319.52	1321.58	1323.64	1325.70	1327.76
190	1329.81	1331.87	1333.93	1335.99	1338.04	1340.10	1342.16	1344.21	1346.27	1348.32

Temp °F	+ 0	+ 1	+ 2	+ 3	+ 4	+ 5	+ 6	+ 7	+ 8	+ 9
200	1350.38	1352.43	1354.48	1356.54	1358.59	1360.64	1362.70	1364.75	1366.80	1368.85
210	1370.90	1372.95	1375.00	1377.05	1379.10	1381.15	1383.20	1385.25	1387.29	1389.34
220	1391.39	1393.44	1395.48	1397.53	1399.57	1401.62	1403.66	1405.71	1407.75	1409.80
230	1411.84	1413.88	1415.92	1417.97	1420.01	1422.05	1424.09	1426.13	1428.17	1430.21
240	1432.25	1434.29	1436.33	1438.37	1440.41	1442.45	1444.48	1446.52	1448.56	1450.59
250	1452.63	1454.66	1456.70	1458.73	1460.77	1462.80	1464.84	1466.87	1468.90	1470.94
260	1472.97	1475.00	1477.03	1479.06	1481.09	1483.12	1485.15	1487.18	1489.21	1491.24
270	1493.27	1495.30	1497.33	1499.35	1501.38	1503.41	1505.43	1507.46	1509.49	1511.51
280	1513.54	1515.56	1517.58	1519.61	1521.63	1523.65	1525.68	1527.70	1529.72	1531.74
290	1533.76	1535.78	1537.80	1539.82	1541.84	1543.86	1545.88	1547.90	1549.92	1551.94

Temp °F	+ 0	+ 1	+ 2	+ 3	+ 4	+ 5	+ 6	+ 7	+ 8	+ 9
300	1553.95	1555.97	1557.99	1560.00	1562.02	1564.04	1566.05	1568.07	1570.08	1572.09
310	1574.11	1576.12	1578.13	1580.15	1582.16	1584.17	1586.18	1588.19	1590.20	1592.21
320	1594.22	1596.23	1598.24	1600.25	1602.26	1604.27	1606.28	1608.28	1610.29	1612.30
330	1614.30	1616.31	1618.31	1620.32	1622.32	1624.33	1626.33	1628.34	1630.34	1632.34
340	1634.34	1636.35	1638.35	1640.35	1642.35	1644.35	1646.35	1648.35	1650.35	1652.35
350	1654.35	1656.35	1658.35	1660.34	1662.34	1664.34	1666.33	1668.33	1670.33	1672.32
360	1674.32	1676.31	1678.31	1680.30	1682.29	1684.29	1686.28	1688.27	1690.26	1692.26
370	1694.25	1696.24	1698.23	1700.22	1702.21	1704.20	1706.19	1708.18	1710.17	1712.15
380	1714.14	1716.13	1718.12	1720.10	1722.09	1724.07	1726.06	1728.04	1730.03	1732.01
390	1734.00	1735.98	1737.96	1739.95	1741.93	1743.91	1745.89	1747.87	1749.86	1751.84

Temp °F	+ 0	+ 1	+ 2	+ 3	+ 4	+ 5	+ 6	+ 7	+ 8	+ 9
400	1753.82	1755.80	1757.78	1759.76	1761.73	1763.71	1765.69	1767.67	1769.65	1771.62
410	1773.60	1775.57	1777.55	1779.53	1781.50	1783.48	1785.45	1787.42	1789.40	1791.37
420	1793.34	1795.32	1797.29	1799.26	1801.23	1803.20	1805.17	1807.14	1809.11	1811.08
430	1813.05	1815.02	1816.99	1818.96	1820.92	1822.89	1824.86	1826.82	1828.79	1830.76
440	1832.72	1834.69	1836.65	1838.62	1840.58	1842.54	1844.51	1846.47	1848.43	1850.39
450	1852.36	1854.32	1856.28	1858.24	1860.20	1862.16	1864.12	1866.08	1868.03	1869.99
460	1871.95	1873.91	1875.87	1877.82	1879.78	1881.74	1883.69	1885.65	1887.60	1889.56
470	1891.51	1893.46	1895.42	1897.37	1899.32	1901.28	1903.23	1905.18	1907.13	1909.08
480	1911.03	1912.98	1914.93	1916.88	1918.83	1920.78	1922.73	1924.68	1926.62	1928.57
490	1930.52	1932.46	1934.41	1936.35	1938.30	1940.25	1942.19	1944.13	1946.08	1948.02

Temp °F	+ 0	+ 1	+ 2	+ 3	+ 4	+ 5	+ 6	+ 7	+ 8	+ 9
500	1949.96	1951.91	1953.85	1955.79	1957.73	1959.67	1961.62	1963.56	1965.50	1967.44
510	1969.37	1971.31	1973.25	1975.19	1977.13	1979.07	1981.00	1982.94	1984.88	1986.81
520	1988.75	1990.68	1992.62	1994.55	1996.49	1998.42	2000.35	2002.29	2004.22	2006.15
530	2008.08	2010.02	2011.95	2013.88	2015.81	2017.74	2019.67	2021.60	2023.53	2025.45
540	2027.38	2029.31	2031.24	2033.17	2035.09	2037.02	2038.94	2040.87	2042.80	2044.72
550	2046.64	2048.57	2050.49	2052.42	2054.34	2056.26	2058.18	2060.11	2062.03	2063.95
560	2065.87	2067.79	2069.71	2071.63	2073.55	2075.47	2077.39	2079.30	2081.22	2083.14
570	2085.06	2086.97	2088.89	2090.81	2092.72	2094.64	2096.55	2098.47	2100.38	2102.29
580	2104.21	2106.12	2108.03	2109.95	2111.86	2113.77	2115.68	2117.59	2119.50	2121.41
590	2123.32	2125.23	2127.14	2129.05	2130.96	2132.86	2134.77	2136.68	2138.58	2140.49

Temp °F	+ 0	+ 1	+ 2	+ 3	+ 4	+ 5	+ 6	+ 7	+ 8	+ 9
600	2142.40	2144.30	2146.21	2148.11	2150.02	2151.92	2153.82	2155.73	2157.63	2159.53
610	2161.44	2163.34	2165.24	2167.14	2169.04	2170.94	2172.84	2174.74	2176.64	2178.54
620	2180.44	2182.34	2184.23	2186.13	2188.03	2189.92	2191.82	2193.72	2195.61	2197.51
630	2199.40	2201.30	2203.19	2205.08	2206.98	2208.87	2210.76	2212.65	2214.55	2216.44
640	2218.33	2220.22	2222.11	2224.00	2225.89	2227.78	2229.67	2231.56	2233.44	2235.33

650	2237.22	2239.11	2240.99	2242.88	2244.77	2246.65	2248.54	2250.42	2252.30	2254.19
660	2256.07	2257.96	2259.84	2261.72	2263.60	2265.49	2267.37	2269.25	2271.13	2273.01
670	2274.89	2276.77	2278.65	2280.53	2282.40	2284.28	2286.16	2288.04	2289.91	2291.79
680	2293.67	2295.54	2297.42	2299.29	2301.17	2303.04	2304.92	2306.79	2308.66	2310.54
690	2312.41	2314.28	2316.15	2318.02	2319.90	2321.77	2323.64	2325.51	2327.38	2329.24
Temp °F	+ 0	+ 1	+ 2	+ 3	+ 4	+ 5	+ 6	+ 7	+ 8	+ 9
700	2331.11	2332.98	2334.85	2336.72	2338.58	2340.45	2342.32	2344.18	2346.05	2347.92
710	2349.78	2351.65	2353.51	2355.37	2357.24	2359.10	2360.96	2362.83	2364.69	2366.55
720	2368.41	2370.27	2372.13	2373.99	2375.85	2377.71	2379.57	2381.43	2383.29	2385.15
730	2387.00	2388.86	2390.72	2392.57	2394.43	2396.29	2398.14	2400.00	2401.85	2403.71
740	2405.56	2407.41	2409.27	2411.12	2412.97	2414.82	2416.68	2418.53	2420.38	2422.23
750	2424.08	2425.93	2427.78	2429.63	2431.48	2433.32	2435.17	2437.02	2438.87	2440.71
760	2442.56	2444.41	2446.25	2448.10	2449.94	2451.79	2453.63	2455.48	2457.32	2459.16
770	2461.00	2462.85	2464.69	2466.53	2468.37	2470.21	2472.05	2473.89	2475.73	2477.57
780	2479.41	2481.25	2483.09	2484.93	2486.76	2488.60	2490.44	2492.27	2494.11	2495.95
790	2497.78	2499.62	2501.45	2503.29	2505.12	2506.95	2508.79	2510.62	2512.45	2514.28
Temp °F	+ 0	+ 1	+ 2	+ 3	+ 4	+ 5	+ 6	+ 7	+ 8	+ 9
800	2516.11	2517.95	2519.78	2521.61	2523.44	2525.27	2527.10	2528.93	2530.75	2532.58
810	2534.41	2536.24	2538.07	2539.89	2541.72	2543.54	2545.37	2547.20	2549.02	2550.85
820	2552.67	2554.49	2556.32	2558.14	2559.96	2561.78	2563.61	2565.43	2567.25	2569.07
830	2570.89	2572.71	2574.53	2576.35	2578.17	2579.99	2581.81	2583.62	2585.44	2587.26
840	2589.08	2590.89	2592.71	2594.52	2596.34	2598.15	2599.97	2601.78	2603.60	2605.41
850	2607.22	2609.04	2610.85	2612.66	2614.47	2616.28	2618.09	2619.90	2621.71	2623.52
860	2625.33	2627.14	2628.95	2630.76	2632.57	2634.37	2636.18	2637.99	2639.79	2641.60
870	2643.41	2645.21	2647.02	2648.82	2650.62	2652.43	2654.23	2656.03	2657.84	2659.64
880	2661.44	2663.24	2665.04	2666.84	2668.65	2670.45	2672.24	2674.04	2675.84	2677.64
890	2679.44	2681.24	2683.03	2684.83	2686.63	2688.43	2690.22	2692.02	2693.81	2695.61
Temp °F	+ 0	+ 1	+ 2	+ 3	+ 4	+ 5	+ 6	+ 7	+ 8	+ 9
900	2697.40									

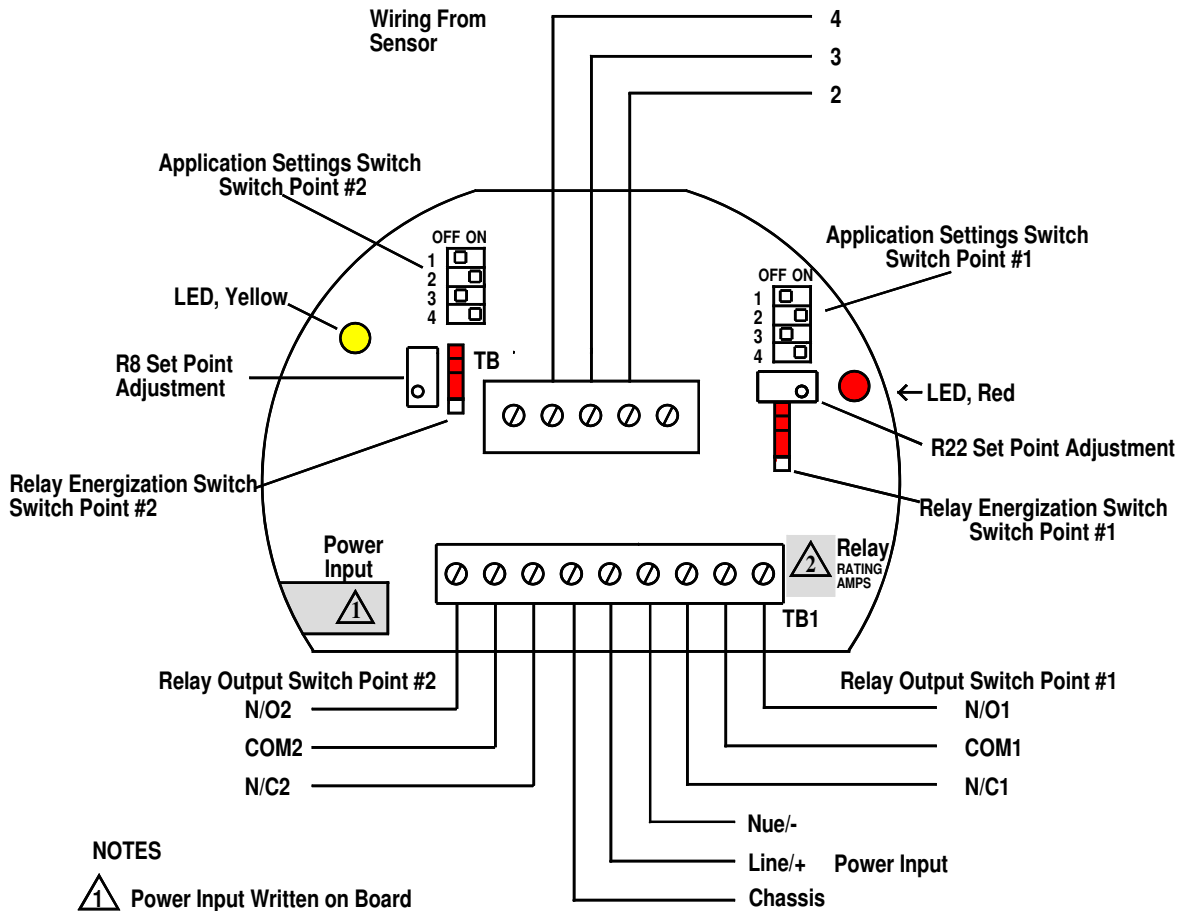

Terminal Number (TB)		
2	3	4
Drain	Red	Black

Application Setting Switch Points 1 & 2	Switch Position		Factory Default
	1	2	
-50 to +130F	ON	ON	
-50 to +220F	OFF	ON	
-50 to +450F	ON	OFF	
-50 to +900F	OFF	OFF	

Relay Energization Settings	Switch Position	Factory Default
Energized Below Set Point		
Energized Above Set Point		

NOTES

Power Input Written on Board

"120 VAC"	90-132 VAC, 4 Watts Max.
"12 VDC"	12 VDC +30%, -10% 300 mA
"24 VAC or VDC"	24 VAC or VDC ±10%, 4 Watts or 150 mA
"240 VAC"	200-240 VAC, 4 Watts Max.

Relay Rating Written on Board

"3"	3 AMP Relay Rated at 120 VAC or 24 VDC Resistive and 2 AMP at 240 VAC
"10"	10 AMP Relay Rated at 120 VAC or 24 VDC Resistive and 5 AMP at 240 VAC

Ameritrol, Inc

1185L Park Center Dr. Vista CA 92081 760-727-7273 800-910-6689

Title **Temperature Switch
Wiring Diagram, Dual Switch Point, X Series Board**

Size A	Drawn by RAL	Drawing No. 2145	Rev 5
------------------	------------------------	----------------------------	-----------------

Scale	Date 2/01	Sheet 1 of 1
-------	---------------------	------------------------