

# AMERITROL, INC.

INSTALLATION  
OPERATION MANUAL  
AND  
WIRING DIAGRAM

LX SERIES  
LIQUID LEVEL SWITCH  
WITH ADDITIONAL  
TEMPERATURE SWITCH

Manual Number: LXTX2117-1

1185L Park Center Dr. Vista CA 92081  
1-760-727-7273  
1-800-910-6689  
1-760-727-7151 Fax  
[www.ameritrol.com](http://www.ameritrol.com)

## OVERVIEW

This unique instrument is both a liquid level switch and a temperature switch. Both the liquid level and temperature switch points are independently adjustable as well as the corresponding relay energization.

The LX series is an electronic point level switch that can be used for simple wet/dry applications or interface applications that are otherwise difficult to detect for other technologies. LX level switches can be used to detect the interface from air/gas and liquids, air/gas and foam, foam and liquids, liquid to liquid interfaces such as oil and water, and solids in a liquid. The device senses the thermal conductivity of the product surrounding the probe. The greater the thermal conductivity the lower the resulting signal output. For example: Air has a low thermal conductivity and a high signal output and water has a high thermal conductivity and low signal output (see table in Operation section).

Some users may find it beneficial to perform a bench calibration before installation. This can be accomplished by obtaining a small sample of the product (assuming the product is safe to handle) and immersing the level sensor into and out of the product while following the steps listed in the Calibration section outlined below.

The additional temperature switch is designed to detect the increase or decrease of temperature.

Please refer to attached wiring diagram for DIP switches and relay energization switch settings (S1 & S2).

- The level switch factory default settings are configured for liquid level and relays energized when wet.
- To change from factory default to relay energized when dry: Reverse red slide switch (S1).
- The application settings switch for temperature is configured as follows: Switches 1 and 2 are off and switches 3 and 4 are on.
- The temperature switch factory default is configured for relay energized below set point.
- To change from factory default relay energization to relay energized above set point: Reverse red slide switch (S2).
- Power input and relay rating are written on the board.

## INSTALLATION

Conduit Recommendation: Do not place level/temperature switch at low point of conduit, because moisture can collect at the low point. A conduit seal may be beneficial in preventing moisture from entering the enclosure and damaging the electronics.

**SIDE MOUNTED-** This point level/temperature switch can be mounted directly into the tank or vessel or in a stand pipe parallel to the vessel. It is recommended that the probe extend into the stand pipe or vessel when used with highly viscous products. A half coupling or thread-o-let attached to the side of the tank or vessel will allow proper insertion. The flats on the sensor can be placed in any orientation but should remain constant once calibration has been done.

**TOP MOUNTED-** The level/temperature switch can be top mounted directly to the tank or vessel. It is recommended a potting "Y" be used on the conduit connection to prevent moisture/condensation from filling the enclosure. The flats on the sensor are for reference only and should remain constant after calibration

**WIRING-** See attached drawing for wiring details.

## OPERATION

The level switch operates by primarily detecting the thermal conductivity of the product surrounding the probe. Air and gases are poor conductors of heat and will create the largest signal output from the sensor. A liquid is a greater conductor of heat than air and will provide a lower output.

The following table lists typical product types and their relative output.

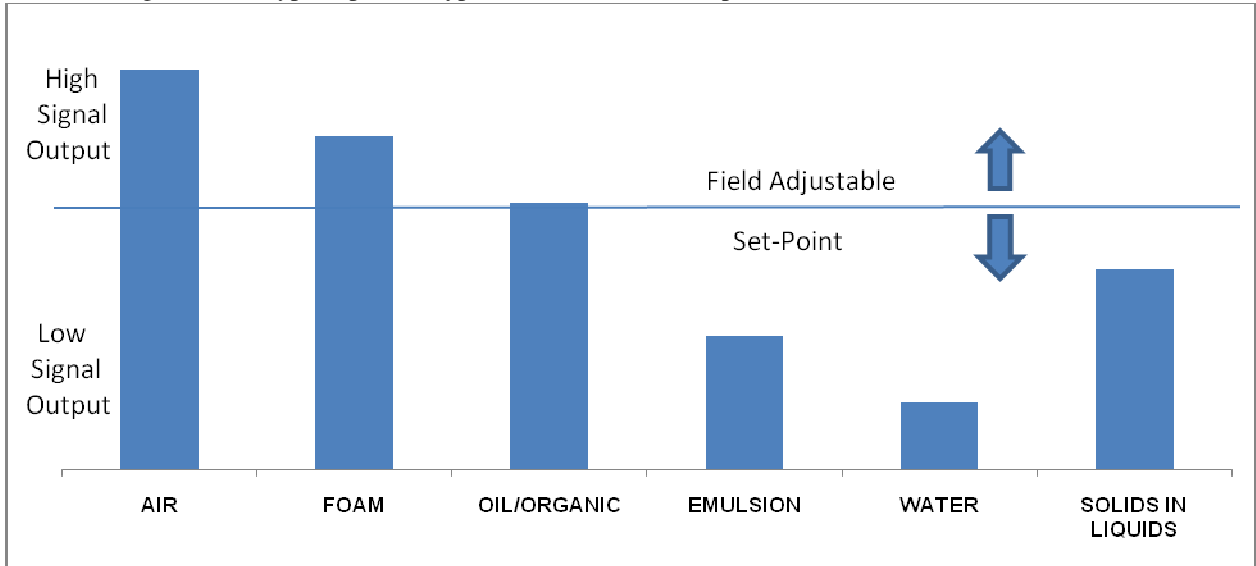

The field adjustable set-point can easily be set to detect interfaces between products with different thermal conductivities.

The relay output can be field selected to be energized when the sensor head is wet or dry. The factory default is for the relay to be energized when wet and can be changed by switching the relay energization switch (S1) as shown on the attached wiring diagram.

## CALIBRATION STARTUP

1. Power the instrument and allow 3 minutes for the sensor head to reach equilibrium.
2. Remove the housing cover observing the safety precautions associated with the area in which the unit is mounted.

## LIQUID LEVEL SWITCH CALIBRATION

The instrument is factory set to detect a wet (water) / dry condition with relay energized when wet. For other applications and relay energization follow steps that correspond with your relay energization requirement.

In applications where it is difficult to change the product level, the following calibration steps may be performed before installation. This can be accomplished by immersing the level sensor into and out of a product sample while following the steps listed in the Calibration section outlined below. This is not necessary, but may be easier in certain situations.

### RELAY ENERGIZED WHEN WET (factory default)

It is assumed that the user will have the relay energized when wet (or in product with low signal output) and will alarm (relay de-energize) when dry (or in product with higher signal output). Please refer to attached wiring diagram for relay energization switch setting.

Adjust the potentiometer (R22 on the wiring diagram) on the circuit board until the red LED changes state, as follows:

If the LED is on: Turn the potentiometer clockwise.

If the LED is off: Turn the potentiometer counterclockwise.

Typical backlash for the potentiometer is 1/8 turn.

Once the red LED on/off location is determined, turn the potentiometer as follows:

**If the sensor is currently exposed to a product that provides a high output**, (as described in operation section) turn the potentiometer clockwise (per product listed below) past the point the red led turns off as follows:

- Air to Liquid (water): 4 turns
- Air to Liquid Organics/hydrocarbons: 2 turns
- Liquid Organics/hydrocarbons to Water: 1 turn
- Emulsion to Water: 1 turn

**If the sensor is currently exposed to a product that provides a low output** (as described in operation section), turn the potentiometer counterclockwise (per product listed below) past the point the red led turns on as follows:

- Liquid (water) to Air: 2 turns
- Liquid Organics/hydrocarbons to Air: 2 turns
- Water to Liquid Organics/hydrocarbons: 1 turn
- Clean liquid to Solids in liquid: 1/2 turn

#### RELAY ENERGIZED WHEN DRY (field change of relay energization switch)

It is assumed that the user will have the relay energized when dry (or in product with higher signal output) and will alarm (relay de-energize) when wet (or in product with low signal output). Please refer to attached wiring diagram for relay energization setting. The relay energization switch (red slide switch: S1) will need to be changed from the factory default setting.

Adjust the potentiometer (R22 on the wiring diagram) on the circuit board until the red LED changes state, as follows:

If the LED is on: Turn the potentiometer counterclockwise.

If the LED is off: Turn the potentiometer clockwise.

Typical backlash for the potentiometer is 1/8 turn.

Once the red LED on/off location is determined, turn the potentiometer as follows:

**If the sensor is currently exposed to a product that provides a high output**, (as described in operation section) turn the potentiometer counterclockwise (turns per product listed below) past the point the red led turns off as follows:

- Air to Liquid (water): 4 turns
- Air to Liquid Organics/hydrocarbons: 2 turns
- Liquid Organics/hydrocarbons to Water: 1 turn
- Emulsion to Water: 1 turn

**If the sensor is currently exposed to a product that provides a low output** (as described in operation section), turn the potentiometer clockwise (per product listed below) past the point the red led turns on as follows:

- Liquid (water) to Air: 2 turns
- Liquid Organics/hydrocarbons to Air: 2 turns
- Water to Liquid Organics/hydrocarbons: 1 turn
- Clean liquid to Solids in liquid: 1/2 turn

## **TEMPERATURE SWITCH CALIBRATION**

The temperature switch uses the liquid level switch reference sensor as its primary sensor. Typically the temperature switch is set at the factory per customer specifications. To field calibrate expose the sensor to desired temperature set-point and adjust as shown below.

Power the instrument and adjust as follows:

### **TO DETECT AN INCREASE IN TEMPERATURE (FACTORY DEFAULT):**

It is assumed that the user will have the relay energized below the set-point and will alarm (relay de-energize) on increasing temperature. Please refer to attached wiring diagram for relay energization programming.

Adjust the potentiometer (R8 on the wiring diagram) on the circuit board until the red LED changes state, as follows:

If the LED is on: Turn the potentiometer clockwise.

If the LED is off: Turn the potentiometer counterclockwise.

Typical backlash for the potentiometer is 1/8 turn.

Locate the point where the relay just turns on and the unit is calibrated.

### **TO DETECT DECREASE IN TEMPERATURE:**

It is assumed that the user will have the relay energized above the set-point and will alarm (relay de-energize) on decreasing temperature. Please refer to attached wiring diagram for relay energization programming. The relay energization switch (red slide switch: S2) will need to be changed from the factory default setting.

Adjust the potentiometer (R8 on the wiring diagram) on the circuit board until the red LED changes state, as follows:

If the LED is on: Turn the potentiometer counterclockwise.

If the LED is off: Turn the potentiometer clockwise.

Typical backlash for the potentiometer is 1/8 turn.

Locate the point where the relay just turns on and the unit is calibrated.

Technical service hours are Monday – Friday from 8:00 AM to 4:30 PM Pacific Standard Time

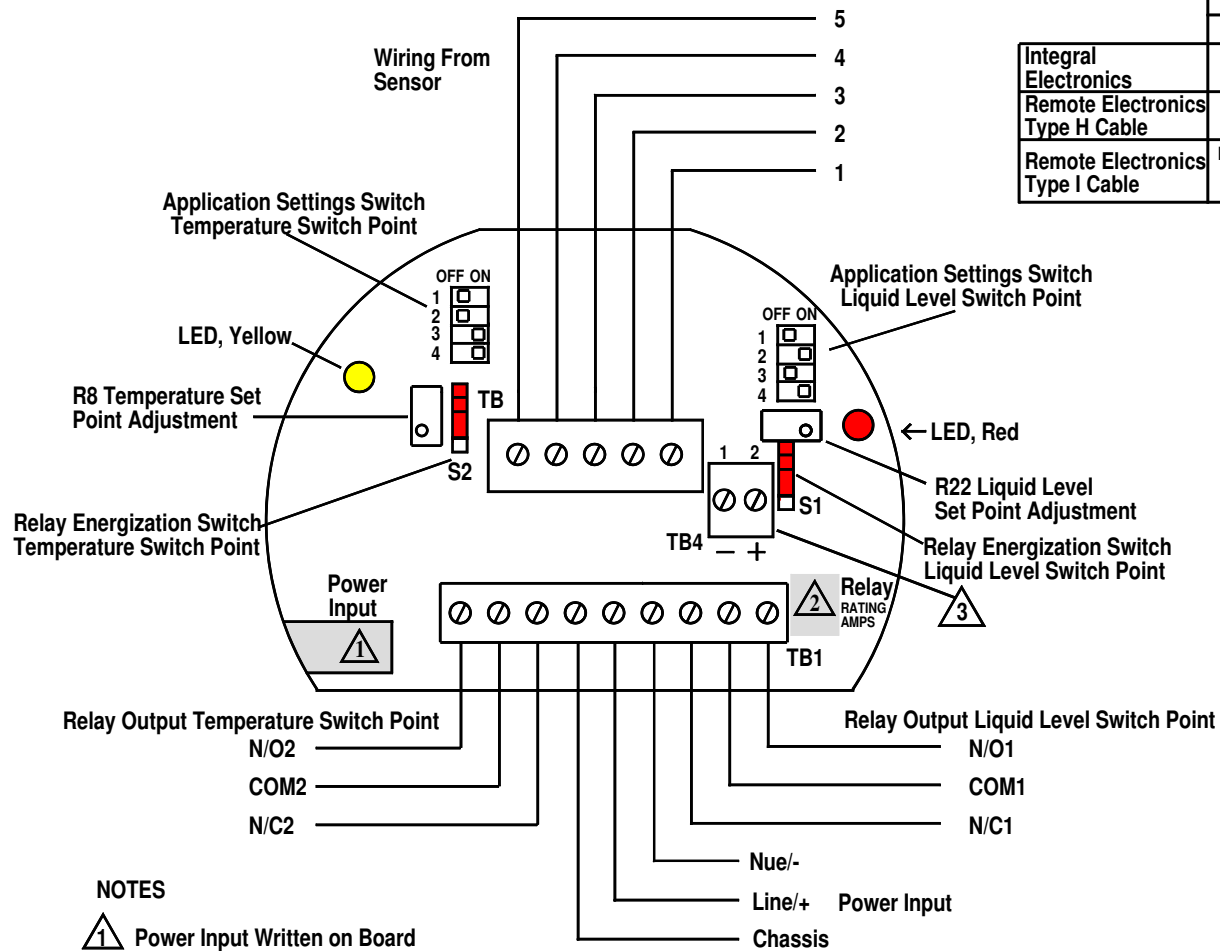

	Terminal Number (TB)				
	1	2	3	4	5
Integral Electronics	Red or Purple	Red or Purple	Yellow or White	Black	Green
Remote Electronics Type H Cable	White	Blue + Drain	Yellow	Black	Green
Remote Electronics Type I Cable	Red of Pair #1 (Red Foil)	Black of Pair #1 + Drain of Pairs #2 and #3	White of Pair #2 (Green Foil)	Black of Pairs #2 and #3	Green of Pair #3 (Blue Foil)

Application Setting Switches 1 and 2	Switch Position			
	1	2	3	4
Liquid Flow Switch	ON	OFF	OFF	ON
Air Flow Switch	OFF	ON	OFF	ON
Liquid Level Switch	OFF	ON	OFF	ON
Temperature Switch	OFF	OFF	ON	ON

Factory Default  
Factory Default

Relay Energization Settings	Switch Position	
Flow Switch		
Energized at Flow	<input type="checkbox"/>	Factory Default
Energized at No Flow	<input type="checkbox"/>	
Level Switch		
Energized when Wet	<input type="checkbox"/>	Factory Default
Energized when Dry	<input type="checkbox"/>	
Temperature Switch		
Energized below Set Point	<input type="checkbox"/>	Factory Default
Energized above Set Point	<input type="checkbox"/>	

**NOTES**

1 Power Input Written on Board

"120 VAC"	90-132 VAC, 4 Watts Max.
"12 VDC"	12 VDC +30%, -10% 300 mA
"24 VAC or VDC"	24 VAC or VDC ±10%, 4 Watts or 150 mA
"240 VAC"	200-240 VAC, 4 Watts Max.

2 Relay Rating Written on Board

"3"	3 AMP Relay Rated at 120 VAC or 24 VDC Resistive and 2 AMP at 240 VAC
"10"	10 AMP Relay Rated at 120 VAC or 24 VDC Resistive and 5 AMP at 240 VAC

3 TB4 for Optional mV Output

**Ameritrol, Inc**  
1185L Park Center Dr. Vista CA 92081 760-727-7273 800-910-6689

Title <b>Liquid Level Switch with additional Temperature Switch Wiring Diagram, Dual Switch Point and/or mV Output, X Series Board</b>			
Size <b>A</b>	Drawn by <b>RAL</b>	Drawing No. <b>2117</b>	Rev <b>2</b>
Scale	Date <b>2/01</b>	Sheet <b>1 of 1</b>	